



QDD60TSC

Electric Tractor 6.0t

Super Towing Capacity, Highly-efficient Performance;
Sit-down Operation, Comfortable & Safe.

EP EQUIPMENT CO.,LTD
www.ep-ep.com



FEATURE

Performance

- AC Traction system, big torque, strong grade ability, powerful traction, can overcome all the uneven working condition.
- AMP connector and durable electric wires greatly reduce malfunctions of components.

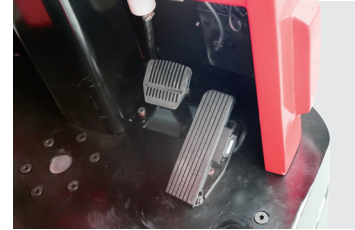

Safety

- Seat switch avoids wrong operation.
- Automatic braking and reverse current braking when foot switch is off or travel switch is neutral.
- Emergency disconnecter will cut off power source to avoid accident when truck goes out of control.
- Water & dust-proof cover under traction motor can effectively extend motor life.
- Hydraulic brake, reverse current brake and mechanical brake.

Operation

- Clear layout and spacious driving room.
- Seat with suspension, more comfortable.
- Steering wheel could be adjustable with big angles to meet operator's needs.
- Big pedal & long support arm makes it comfortable & safe.
- The layout of steering wheel, brake, foot pedal, and other instruments are the same as the electric forklift, which makes it convenient to operate.
- Button at the rear of tractor allows coast travel.

Maintenance

- AC traction motor, maintenance free.
- Hour meter and battery indicator will remind the operator of battery charging.
- Easily remove the back cover by only loosening four bolts; Easy access for maintenance.
- Control system allows easy trouble-shooting.
- Low voltage lift cut off design protects the battery.

Electric tractor 6.0t

QDD60TSC

Distinguishing mark				
1.1	Manufacturer			EP
1.2	Model designation			QDD60TSC
1.3	Drive unit			Electrics
1.4	Operator type			seated
1.5	rated capacity	Q	kg	6000
1.7	Rated drawbar pull	F	N	1200
1.9	Wheelbase	y	mm	1110
Weight				
2.1	Service weight (include battery)		kg	1150
2.3	Axle loading, unladen Driving/loading		kg	500/ 650
Types,Chassis				
3.1	Tyre type driving wheels/Loading wheels			solid rubber
3.2	Tyre size, driving wheels (diameter×width)		mm	4.00-8
3.3	Tyre size, loading wheels (diameter×width)		mm	4.00-8
3.5	Wheels, number driving/loading (x=drive wheels)		mm	1/2x
3.6	Track width, front,driving side	b10 (mm)	mm	/
3.7	Track width,rear,loading side	b11 (mm)		869
Dimensions				
4.7	Height of overhead guard (cabin)	h6 (mm)	mm	1320
4.8	Seat height/standing height	h7 (mm)	mm	947
4.12	Tow coupling height	h10(mm)	mm	361(221/291/431)
4.13	Loading height, unladen	h11(mm)	mm	591
4.16	Length of loading surface	l3(mm)	mm	450
4.17	Overhang	l5(mm)	mm	471
4.18	Width of loading surface	b9 (mm)	mm	700
4.19	Overall length	l1 (mm)	mm	1966
4.21	Overall width	b1/b2(mm)	mm	1010/990
4.32	Ground clearance, center of wheelbase	m2 (mm)	mm	150
4.35	turning radius	Wa (mm)	mm	1850
4.36	Internal turning radius	b13 (mm)	mm	1182
Performance data				
5.1	Travel speed, laden/ unladen		km/ h	7/17
5.5	Drawbar pull, laden/unladen		N	1200
5.6	Max. drawbar pull, laden/unladen		N	4500
5.10	Service brake type			Hydraulic / Mechanical
	Park brake type			Mechanical
Electric-engine				
6.1	Drive motor rating S2 60 min		kW	6
6.3	The maximum allowed size battery		mm	/
6.4	Battery voltage/nominal capacity K5		V/ Ah	48/ 275 (max325)
6.5	Battery weight		kg	506
Addition data				
8.1	Type of drive unit			AC
10.5	Steering type			Electronic
10.7	Sound pressure level at the driver's ear		dB (A)	70
10.8	Towing coupling, type DIN 15170			Bolt type

If there are improvements of technical parameters or configurations, no further notice will be given.
The diagram shown may contain non-standard configurations.

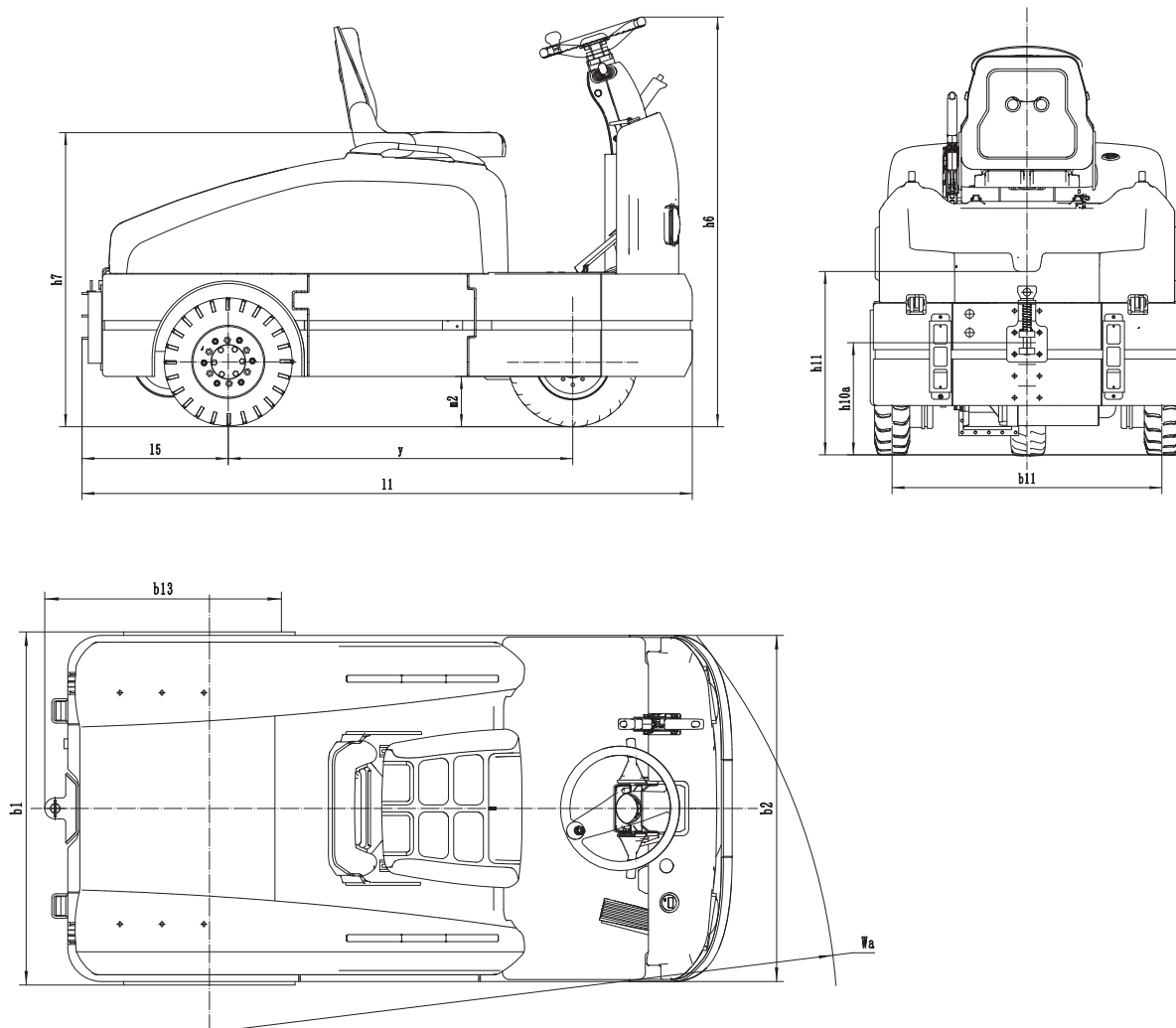

Option

Options	QDD60TSC
Driving wheel	●
Battery capacity	○
Lateral change battery	●
Front light	●
Warning light	○
Steering light	●
Cockpit	○
Side to pull the car	○
Note: ● standard ○ option — NA	